

## DYNACODE II

Perfection in packaging printing.

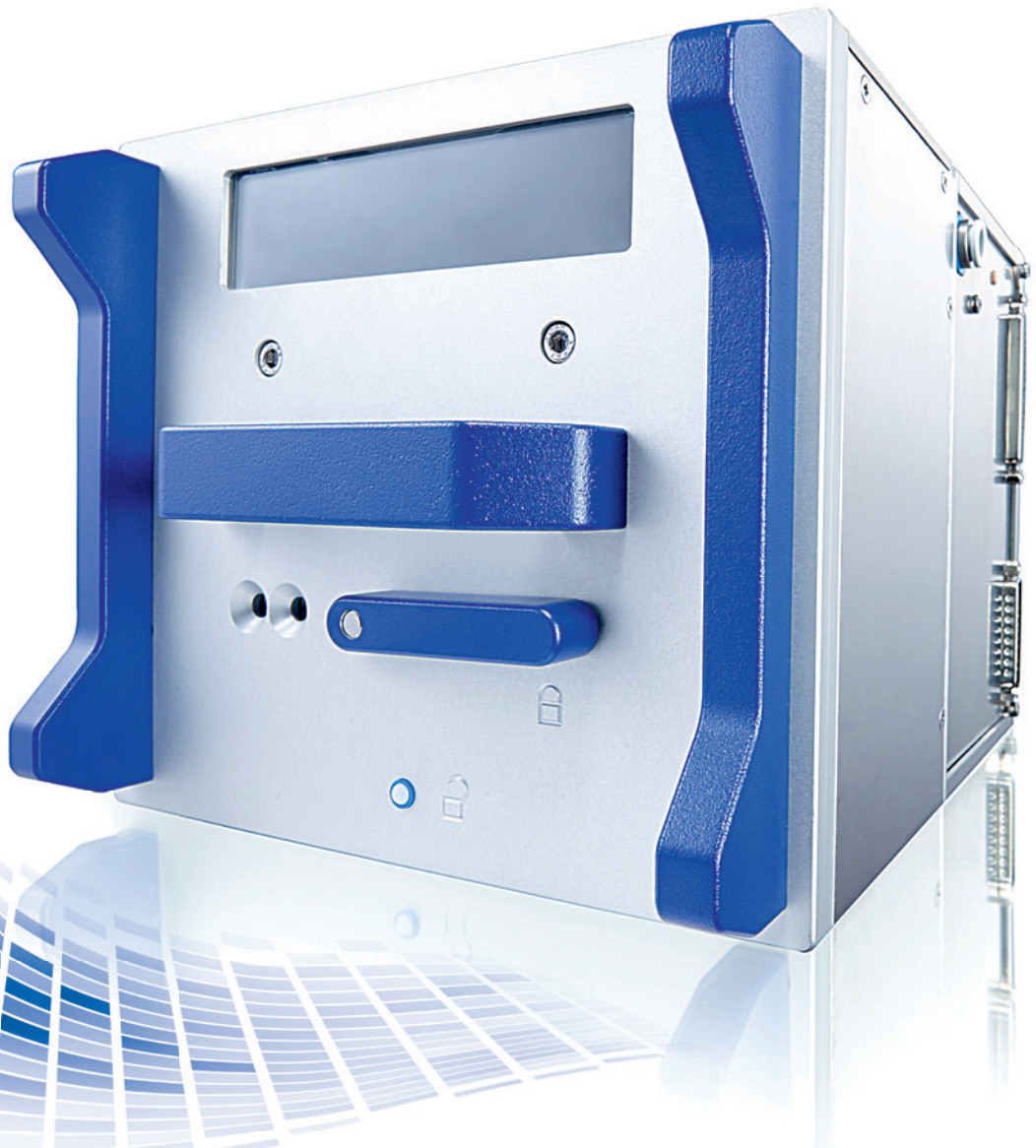

## Dynacode II – the further advancement of a successful series.

With our established Dynacode series, we set new standards for the printing of foil packaging. The keyword here is flexibility: mode, speed, print resolution, installation position - there are no limits regarding the wishes and needs of our customers. Therefore our new product line Dynacode II is nothing other than the logical continuation of a success story. Below we will show you all operating modes and product components of the system.

### > Continuous mode

---

When printing continuously the printhead stands still while the packaging foil is guided through. Printing takes place during the operation of packaging machine.

### > Intermittent mode

---

When printing intermittently the printhead moves over the foil in order to move back to initial position. Printing takes place while the machine is at a short standstill, frequently while packaging is being filled.



### Control unit

---

The control unit of the Dynacode II features an intuitive user interface with icon buttons and a 7" colour touch-screen display with preview for verifying the layout. This makes it very easy to keep control over the print configuration.



### Bracket system

---

Our bracket systems permit an uncomplicated integration in your packaging line. The newly positioned return pulleys and the registration unit which can be mounted on all sides, offer a broad scope of variation of the foil run.

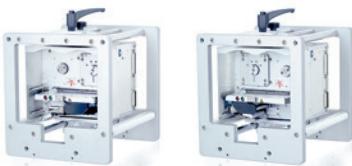

### Left and right version

---

Again for Dynacode II we offer the bracket systems as a left-mounted and right-mounted variant. Horizontal and vertical mounting is virtually unlimited: maximum flexibility.

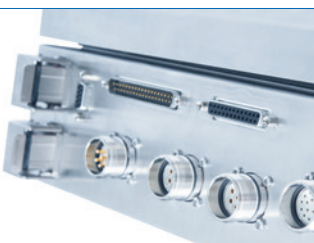

### IP version

---

The splash-proof version offers additional protection in harsh production environments. During the cleaning process neither print module nor control unit must be dismantled or covered. The cleaning cassette necessary for this can simply replace the ribbon cassette within seconds. The IP version is not available with touch-screen display.

	Dynacode II 53	Dynacode II 107	Dynacode II 128
<b>Printing</b>			
Print width	max 53.3 mm	max 106.6 mm	max 128 mm
Print length continuous mode intermittent mode	6000 mm 75 mm	3000 mm 75 mm	3000 mm 75 mm
Print speed continuous mode intermittent mode	50 – 800 mm/s 50 – 600 mm/s	50-600 mm/s 50-600 mm/s	50-450 mm/s 50-600 mm/s
Back speed	intermittent mode only: max 600 mm/s		
Passage width bracket system	customized		
Resolution	300 dpi	300 dpi	300 dpi
Printhead	Corner Type	Corner Type	Corner Type
<b>Dimensions (width x height x depth)</b>			
Print mechanics without bracket system with bracket system	204 x 182 x 235 mm dependent on passage width	204 x 182 x 290 mm dependent on passage width	204 x 182 x 310 mm dependent on passage width
Control unit	251 x 96 x 207 mm	251 x 96 x 207 mm	251 x 96 x 207 mm
Connecting cables to mechanics	2.5 m	2.5 m	2.5 m
<b>Weight</b>			
Print mechanics	9.5 kg	11 kg	11.7 kg
Electronics with cable	5.5 kg	5.5 kg	5.5 kg
<b>Acoustic emission (distance 1 m)</b>			
Average sound power level	60 dB(A)	65 dB(A)	68 dB(A)
<b>Transfer ribbons</b>			
Ink	outside/inside (option)	outside/inside (option)	outside/inside (option)
Roll diameter	max 98 mm	max 82 mm	max 75 mm
Core diameter	25.4 mm / 1"	25.4 mm / 1"	25.4 mm / 1"
Length	max 900 m	max 600 m	max 450 m
<b>Interfaces</b>			
Serial	RS-232C (max 115,200 baud)		
USB	2.0 High Speed Slave		
Ethernet	10/100 Base T, LPD, RawIP-Printing, DHCP, HTTP, FTP		
2 x USB Master	connection for external USB keyboard and memory stick		
<b>Connection values</b>			
Pneumatic connection	min 6 bar dry and oil-free		
Nominal voltage	110 – 230 V / 50 – 60 Hz		
Nominal current	230 V / 1.5 A – 110 V / 3 A		
Fuse values	2x T4A 250 V		
<b>Operating conditions</b>			
Temperature	5 – 40 °C		
Relative humidity	max 80 % (non-condensing)		
<b>Fonts</b>			
Font types	6 bitmap fonts   8 vector fonts/TrueType fonts   6 proportional fonts   more fonts on demand		
Character sets	Windows 1250 to 1257, DOS 437, 850, 852, 857   all West and East European, Latin, Cyrillic, Greek and Arabic characters are supported / more character sets on demand		
Bitmap fonts	size in width and height 0.8 – 5.6   zoom 2 – 9   orientation 0°, 90°, 180°, 270°		
Vector fonts/TrueType fonts	6 BITSTREAM® fonts   size in width and height 1 – 99 mm variable zoom   orientation 360° in steps of 90°		
Font attributes	dependent on font type – bold, italic, inverse, vertical		
Character spacing	variable		
<b>Bar codes</b>			
1D bar codes	CODABAR, Code 128, Code 2/5 interleaved, Code 39, Code 39 extended, Code 93, EAN 13, EAN 8, EAN ADD ON, GS1-128, Identcode, ITF 14, Leitcode, Pharmacode, PZN 7 Code, PZN 8 Code, UPC-A, UPC-E		
2D bar codes	Aztec Code, CODABLOCK F, DataMatrix, GS1 DataMatrix, MAXICODE, PDF 417, QR Code		
GS1 bar codes	GS1 DataBar Expanded, GS1 DataBar Limited, GS1 DataBar Omnidirectional, GS1 DataBar Stacked, GS1 DataBar Stacked Omnidirectional, GS1 DataBar Truncated		
	all bar codes are variable in height, module width and ratio   orientation 0°, 90°, 180°, 270° check digit and human readable line optional.		

Right version . Intermittent mode

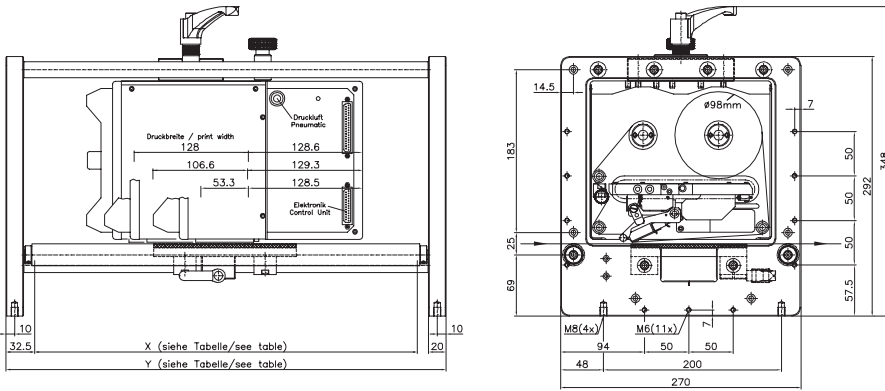

Durchlassbreite (X) Passage width (X)	250	340	430	470	620	770
Rahmenbreite (Y) Frame width (Y)	315	405	495	535	685	835

Right version . Continuous mode

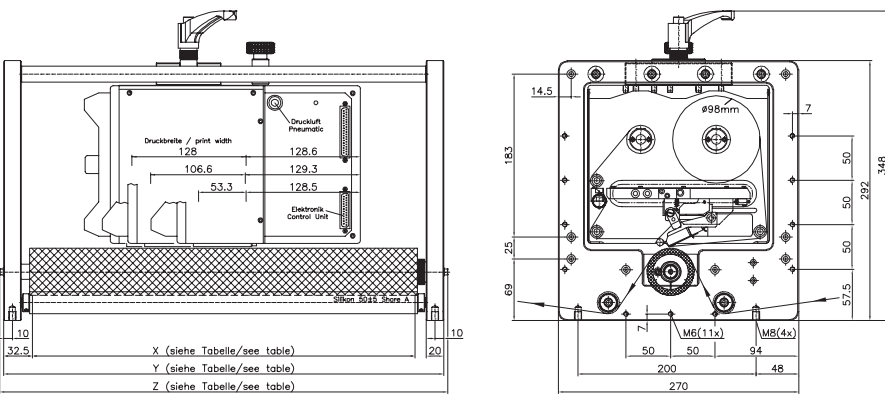

Durchlassbreite (X) Passage width (X)	250	340	430	470	620	770
Rahmenbreite (Y) Frame width (Y)	315	405	495	535	685	835
Gesamtbreite (Z) Overall width (Z)	323,8	413,8	503,8	543,8	693,8	843,8

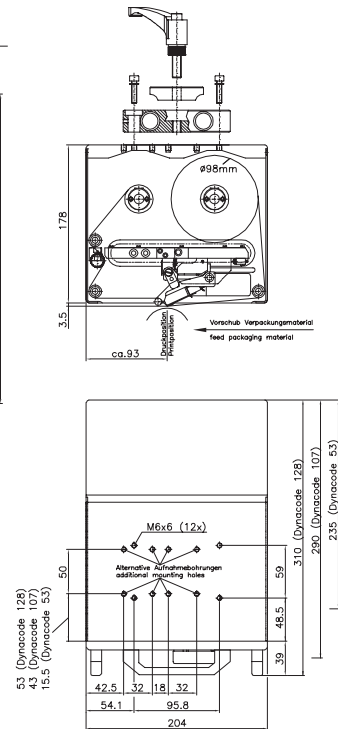

Control unit

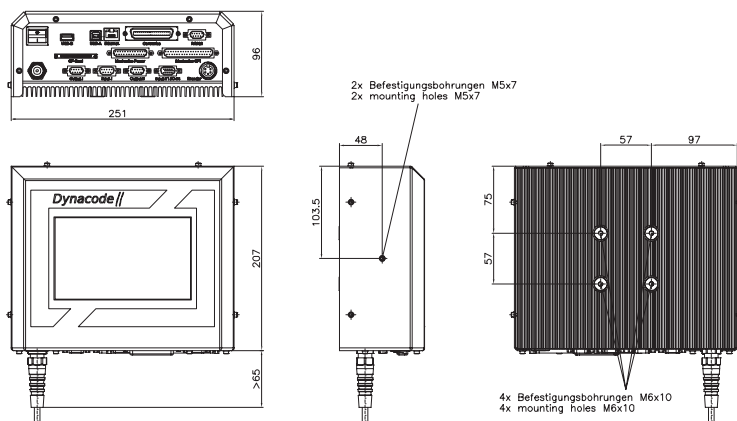

- Dynacode II is as well available as left version (mirrored)
- all measurements in mm
- subject to technical changes



# DYNACODE II

efficient . flexible . fast

- > Intermittent and continuous mode freely selectable
- > Left and right version available
- > Up to 900 m transfer ribbon for long production running times
- > Display of remaining transfer ribbon for quick ribbon changes
- > Optimal transfer ribbon usage
- > All common interfaces for fast data exchange
- > Minimum of wear parts
- > Intuitive graphical user interface with icon buttons
- > WYSIWYG display with preview for verifying the layout
- > 7" touch-screen colour display



Local retailer

**Branches:**

**Sales office Bavaria**

Marienplatz 8a . 83043 Bad Aibling

Phone +49 8061 3498888 . Fax +49 8061 3499127 . [rstreck@carl-valentin.de](mailto:rstreck@carl-valentin.de)

**Sales office Spain**

Calle historiador Vedia 14 5ºB . 15004 La Coruña

Phone +34 881 103163 . Mobile +34 609 022 241 . [mlano@carl-valentin.es](mailto:mlano@carl-valentin.es)

**Sales office Switzerland**

Swiss Business Haus . Moosackerstraße 75 . 8105 Regensdorf

Phone +41 61 9739641 . Mobile +41 79 7448436 . [info@carl-valentin.ch](mailto:info@carl-valentin.ch)

**Sales office Greece**

AristonPrint . Agisilaou & Adrianoupoleos 12 . 62123 Serres

Mobile +30 698 011 6703 . Mobile +30 698 011 6730 . [info@aristonprint.com](mailto:info@aristonprint.com)



Carl Valentin GmbH

Neckarstraße 78–86 u. 94

78056 Villingen-Schwenningen

Phone +49 7720 9712-0 . Fax +49 7720 9712-9901

[info@carl-valentin.de](mailto:info@carl-valentin.de) . [www.carl-valentin.de](http://www.carl-valentin.de)

